

S55XB and S55XBE Series Viewing Heads

SPECIFICATION DATA

APPLICATION

The Honeywell S55xx product family comprises UV/IR viewing heads intended for flame scanning applications. These viewing heads must be used with the P52x or P53x family of signal processors to create a flame scanning system. See chart below for viewing head part number options, and refer to the respective signal processor manual for connection, set up and operation.



Table 1. Available models and associated features.

Model	Amphenol-Tuchel Connector	Turck Connector	Quick Disconnect	Pipe Fit Connection with 50-ft Pigtail	UVTron Sensor	IR Sensor
S550B	X		X		X	X
S550BE		X	X		X	X
S550BE-PF				X	X	X
S552B	X		X			X
S552BE		X	X			X
S552BE-PF				X		X
S556B	X		X		X	
S556BE		X	X		X	
S556BE-PF				X	X	

All models include the following:

1. All models include Electronic self-check.
2. Flicker Frequency filter settings available for IR sensor models.
3. Gain Selection available through Signal Processor.

Contents

Application	1
Specifications	2
Installation	5
Accessories	8
Operation	9
Maintenance	10
Safety Manual	14



SPECIFICATIONS

Dimensions: See Fig. 1 and Fig. 2.

Electrical

Input Power: 24VDC +10%, 100mA (powered from Signal Processor)

Environmental

Sealing: Viewing Head Housing

Operational Ambient Temperature: -40° F to 158° F
(-40° C to 70° C)

Optical

Angle of View:

IR 1.0°

UV 3.0°

Cable & Connectors - S55xBE Viewing Heads

New Installations - Highest level of EMI shielding available:
ASY55XBE --> 50 foot C330S cable with molded connector.
ASY55XBE-200 --> 200 foot C330S cable with molded connector.

Field Wire-able Connector w/sleeve options - S55xBE Viewing Heads

Not recommended for new installations.

R-518-09 --> connector accepts 10-12mm cable (existing C328 cable).

R-518-11 --> connector accepts 6-8mm cable (C330 or C330S cable).

Cable & Connectors - S55xB Viewing Heads

R-518-08 --> connector accepts 10-12mm cable (existing C328 cable).

Mounting: 1 in. NPT female

Approvals

S55XB Models (Connector series, Pipe fit series [-PF])

CSA for CLASS I, DIV 2, GROUPS A, B, C, D, T5
FM 7610
SIL 3 "Fit for Use"

S55XBE Models (Connector series, Pipe fit series [-PF])

CSA for CLASS I, DIV 2, GROUPS A, B, C, D, T5
FM 7610/ NEMA 4X and CLASS 1, DIV 2, GROUPS A, B, C, D & T5
SIL 3 "Fit for Use"

IECEX CSA 10.0010 Ex nA IIC T5 Gc

-40<Ta<70°C, -40<TA<158°F

NOTE: Use of a connector sleeve required for IECEX (included with S55xBE product). Refer to the Viewing Head Wiring section.

Signal Processor Compatibility

The viewing heads described in this manual are compatible with P522AC or DC models, P531AC or DC models, and P532AC or DC models. All P531 and P532 signal processors are fully compatible with the viewing heads described in this manual.

Model S550B and BE General Description

The Honeywell Model S550B/BE is a dual channel, state-of-the-art flame monitoring viewing head capable of monitoring both the UV (ultraviolet) and IR (Infrared) radiation of a flame. This is accomplished by utilizing two types of detectors, an IR solid state sensor and a UV Photo detector, together with a unique dichroic beam-splitting mirror.

The S550B/BE produces output pulse rates proportional to the flame signal strength; the pulse rates are displayed at the front panel of the signal processor, and at the rear of the viewing head. The S550B/BE displays the two most significant digits of the pulse count shown on the connected signal processor unit. The upper readout displays the UV count in green digits, and the lower readout displays the IR count in red. This information can readily be used to achieve maximum flame signal strength while aiming and sighting the viewing head.

Certain parameters in the S550B/BE, S552B/BE and S556B/BE viewing heads can be selected or adjusted remotely from the front panel of the connected signal processor. These parameters are:

a) UV gain	0-99
b) Filter Selection	1: 16Hz
	2: 24Hz
	3: 33Hz
	4: 52Hz
	5: 75Hz
	6: 100Hz
	7: 155Hz
	8: 215Hz
c) IR gain	0-699

Once adjusted, the new parameters are stored in an EEPROM in the connected signal processor.

Model S552B and BE General Description

The S552B/BE viewing head is designed for IR sensing only. It is basically an S550B/BE without the UV capability, and a single line display. The S552B/BE display shows the two most significant digits of the IR pulse count in red, as shown on the connected signal processor unit. The Signal Processor detects and identifies the viewing head model to which it is connected, and will only allow adjustments related to that model to be performed. In the Model S552B/BE, these adjustments are:

a) Filter Selection	1-8
b) IR gain	0-699

Model S556B and BE General Description

The S556B/BE viewing head is designed for UV sensing only. It is basically an S550B/BE without the IR capability and a single line display. The S556B/BE display shows the two most significant digits of the UV pulse count in green, as shown on the connected signal processor unit.

The Signal Processor detects and identifies the viewing head model to which it is connected, in this case the model S556B/BE, and will only allow adjustments related to that model to be performed. In the Model S556B/BE, this adjustment is:

a) UV gain	0-99
------------	------

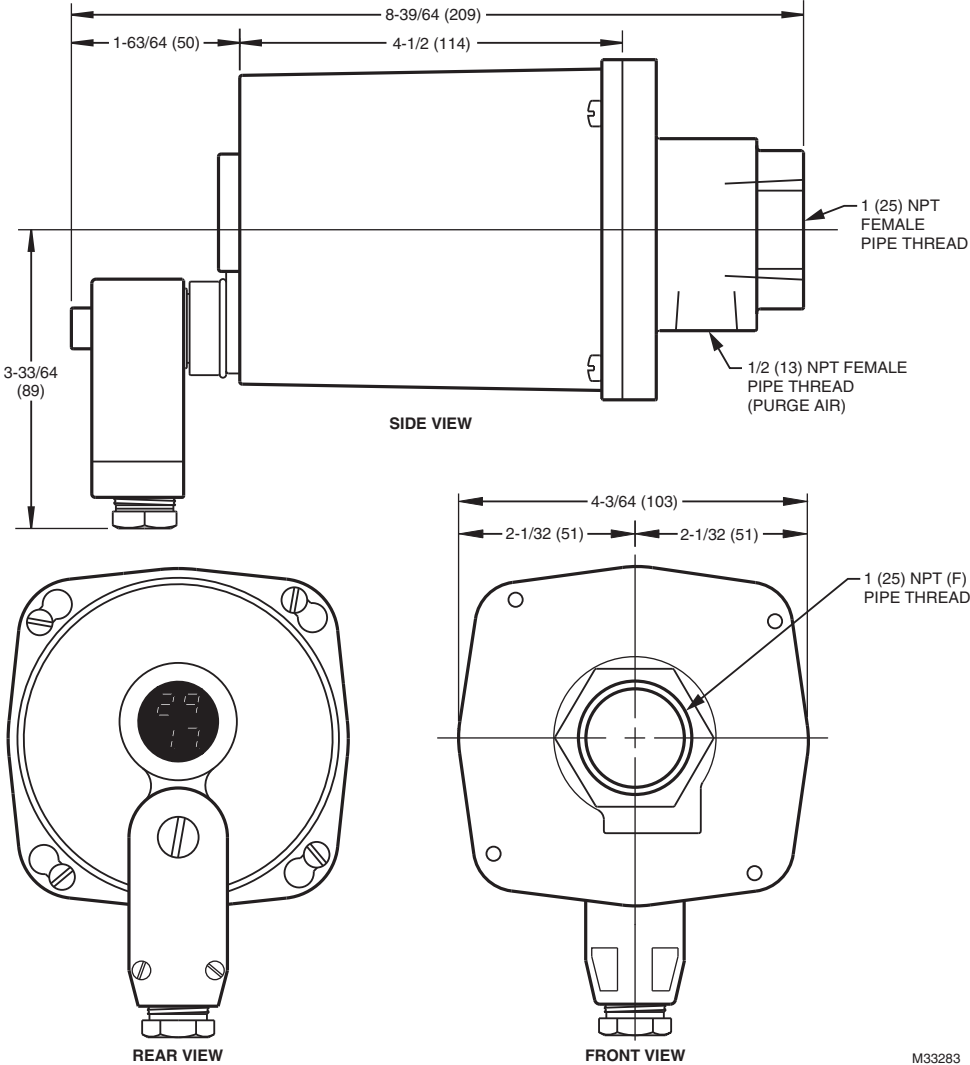

M33283

Fig. 1. S550B, S552B and S556B dimensions in. (mm).

S55XB AND S55XBE SERIES VIEWING HEADS

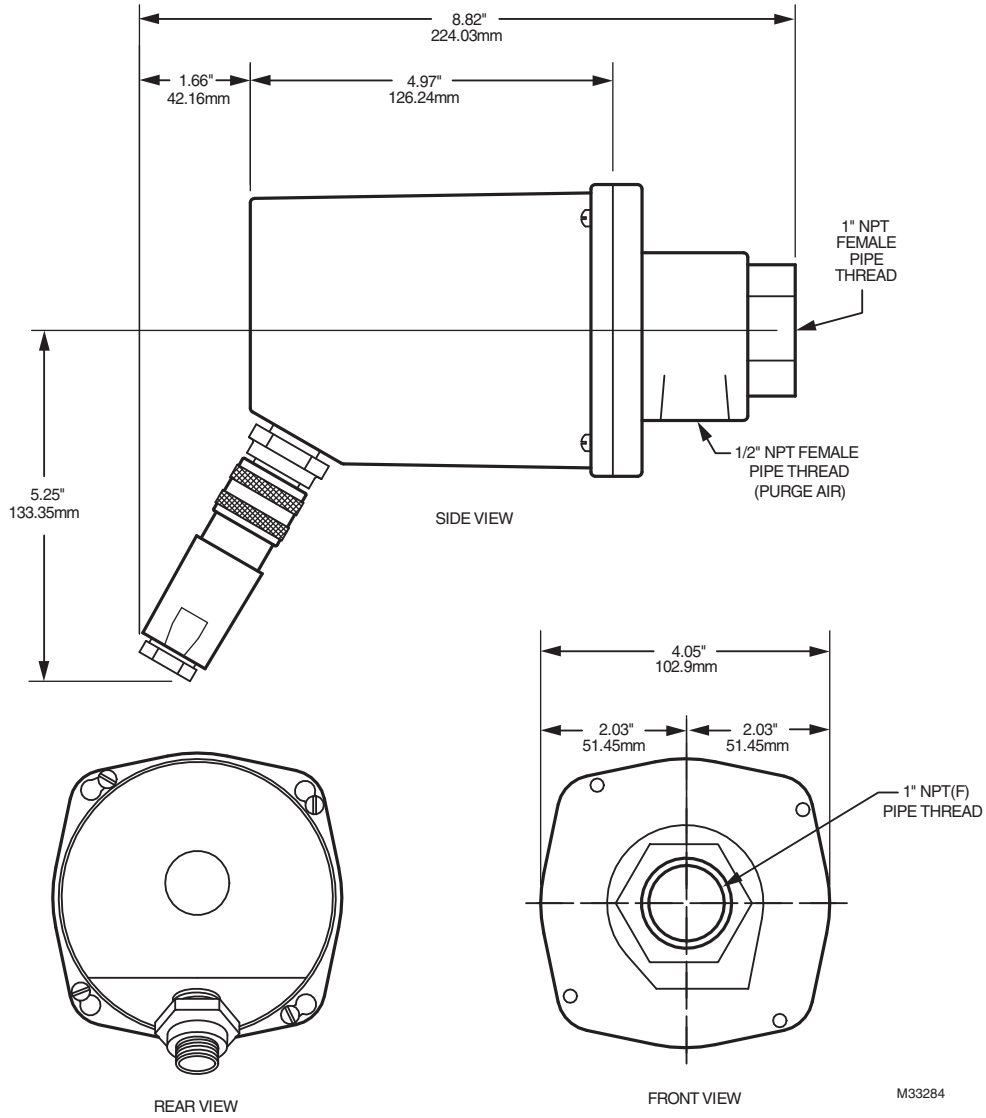

Fig. 2. S550BE, S552BE, and S556BE dimensions in. (mm).

INSTALLATION

Grounding and Shielding

NOTE: Installer must be a trained, experienced flame safeguard service technician and should be familiar with the equipment operation and limitations and be aware of any applicable local codes and regulations.

1. The viewing head and all associated cable/conduit must be at least 12 inches (31 cm) from any source of high energy or voltage (for example, igniter equipment).
2. Install a ground wire from the ignition transformer case to the igniter assembly.
3. Minimize length of the igniter cable between ignition transformer and point of spark. Ensure all igniter wires and cables show no signs of wear. Replace any igniter cables or wires that are frayed or cracked.
4. The viewing head must be electrically isolated from the burner front.
 - a. Electrical isolation can be accomplished by installing an Ultem nipple (R-518-12) or an Ultem locking coupler adapter (R-518-PT12 or R-518-PT12L) in conjunction with a locking coupler (R-518-CL12-HTG or R-518-CL12-PG) between the viewing head flange and the burner mount.
 - b. The purge air line should also be isolated from the viewing head. This can be accomplished by installing any insulating material, for example a rubber hose, in between the purge air line and the viewing head.
5. The viewing head housing may be attached to earth ground, but care must be taken to ensure earth ground at housing, and ground at signal processor are the same potential. Damage to the signal processor or cable can result if these two potentials are different.

Viewing Head Wiring

Viewing heads are wired to the appropriate terminals located on the bottom of the P522, P531 and P532 signal processors. The terminals are listed functionally in Table 2.

Table 2. Terminal Descriptions

Terminal	Description
GND	Power Ground
+V	+24VDC Power to Viewing Head
SC	Shutter Drive Signal to Viewing Head
SIG	Flame Signal from Viewing Head
SIG GND	GND Shield

Cable & Connectors - S55xBE Viewing Heads

New Installations - Highest level of EMI shielding available:
 ASY55XBE --> 50 foot C330S cable with molded connector.
 ASY55XBE-200 --> 200 foot C330S cable with molded connector.

Field Wire-able Connector w/sleeve options - S55xBE Viewing Heads.

Not recommended for new installations.

- R-518-09 --> connector accepts 10-12mm cable (existing C328 cable).
- R-518-11 --> connector accepts 6-8mm cable (C330 or C330S cable).

Cable & Connectors - S55xB Viewing Heads

R-518-08 --> connector accepts 10-12mm cable (existing C328 cable).

See Fig. 4 for S55xBE connections, and Fig. 3 for S55xB connections.

S55XB AND S55XBE SERIES VIEWING HEADS

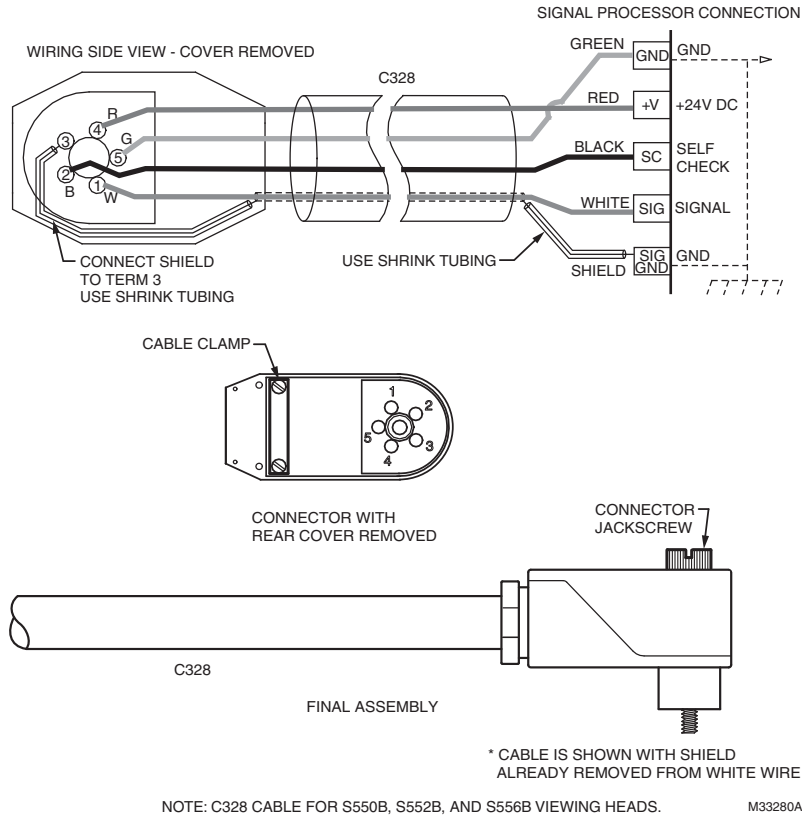

Fig. 3. Cable & Connections for the S550B, S552B, and S556B viewing heads.

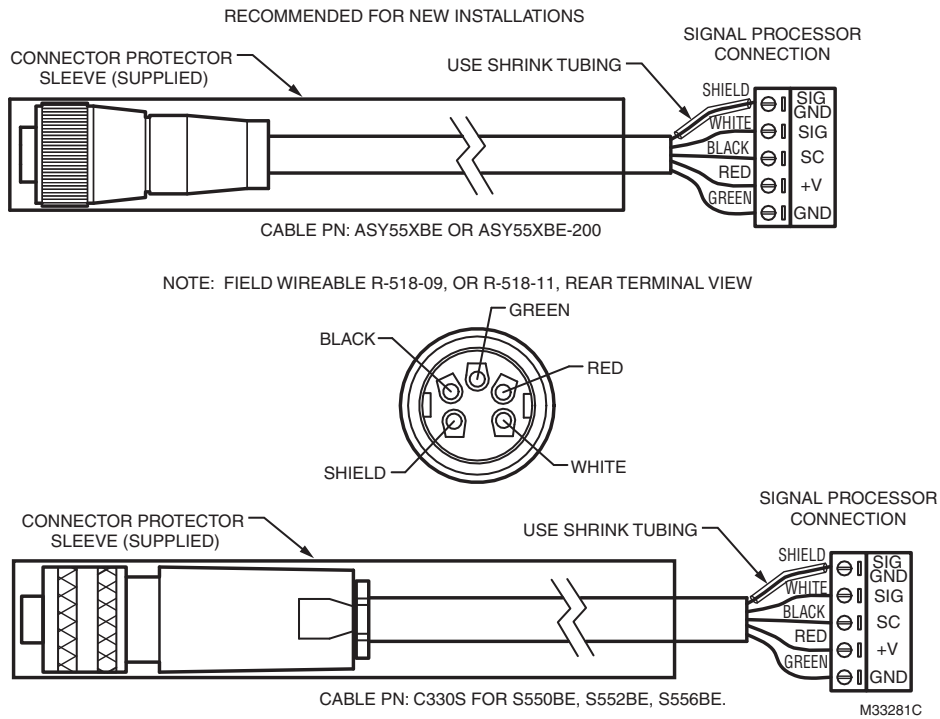

Fig. 4. Cable & Connections for the S550BE, S552BE, and S556BE viewing heads.

IMPORTANT

Source impedance resistor required at the signal processor between SC and SIG GND terminals for proper signal transmission. For resistor value and wiring instructions, refer to the applicable signal processor manual.

NOTES:

- The shield is connected to the SIG GND pin of signal processor. The shield must be foil and braid type with drain wire >22g in order to maintain electrical path. It is recommended that Honeywell C330S cable be used for all new installations.
- A source impedance resistor is required at the signal processor between the SC and SIG GND terminals for proper signal transmission. For resistor value and wiring instructions, refer to the applicable signal processor manual.
- Shrink tubing is required on the SIG GND wire at both ends.
- Use the provided connector protection sleeve when installing the S55XBE connector. Use of the connector sleeve is required for IECEx approval.

Connection of the Honeywell type cable to the field wireable plugs is shown in Fig. 3 and 4, and should be done as follows:

- Remove the cable entry nut from the plug housing.
- Remove the rubber grommet and flat sealing washer or retainer.
- With a pair of long-nosed pliers remove the center ring only of the rubber grommet.
- 1. Strip 2 inches of the cable outer cover back carefully so that shield under jacket is not damaged.
- 2. Slide the shield back until a bulge develops close to where the wire exits the cable outer covering.
- 3. Carefully spread shield at the bulge, and separate from other wires.
- 4. If C330S cover drain wire with shrink tubing, and use for connector shield location. If C330, cover braided shield with shrink tubing and use for connector shield location.
- 5. Slide the nut (with threads toward the cable end), the washer or retainer and the grommet approximately six inches onto the cable.

6. Slip the cable through the bottom opening of the connector making sure that the cable outer jacket is secure under the cable clamp and tighten the two screws on the cable clamp.
7. Reassemble the grommet, flat washer, and cable entry nut and tighten.
8. Strip each wire 3/8" as shown in the assembly drawing Fig. 5 on page 7.
9. Proceed to wire the connector as follows: (Refer to Fig. 3 and 4 for terminal locations.)
 - a. Insert the prepared white wire "SIG" from the cable into terminal location at connector shown in figure. Tighten retaining screw.
 - b. Insert the prepared black wire "SC" from the cable into terminal location at connector shown in figure. Tighten retaining screw.
 - c. Insert the prepared heat shrunk shield wire "SIG GND" from the cable into terminal location at connector shown in figure. Tighten retaining screw.
 - d. Insert the prepared red wire "+24V" from the cable into terminal location at connector shown in figure. Tighten retaining screw.
 - e. Insert the prepared white wire "GND" from the cable into terminal location at connector shown in figure. Tighten retaining screw.
 - f. If using the Amphenol-Tuchel plug, assemble the back of the plug and insert the jackscrew through plug assembly. If using the Turck connector, screw the connector body to the plug front.
 - g. For the S55XBE viewing heads, slide the connector protective sleeve over the connector.

The cable at the signal processor end should be prepared in a similar way to the plug end. Follow the wiring connections as shown in Fig. 3 and 4, making sure that the shield does not touch the other adjacent terminals.

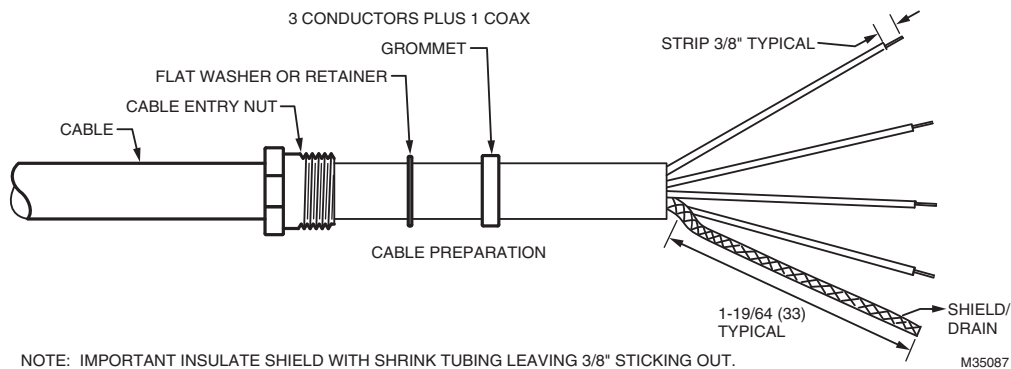

Fig. 5. C330S & C330 Cable Preparation.

Mounting and Sighting

Mounting is 1-in. NPT (F) with a 1/2-in. NPT (F) purge air connection. Before beginning the actual installation, determine the best location for mounting the viewing head based upon the following factors:

Pressure

The viewing head lens will withstand 5 psi. If the lens assembly is exposed to greater than 5 psi through the sight pipe or process connection, then an isolation unit must be used. Honeywell isolation units with purge air entrance are

available as accessories; ISO-UNIT, ISO-UNITSS and ISO-UNITHPGT. Each has a quartz window, two 1-in. NPTF connections and a 1/2-in. NPTF purge port.

Temperature

The viewing head can withstand an ambient temperature of 158F (70C). The case temperature of the housing must not exceed 158F (70C).

Purge air will help reduce conducted heat through the sight pipe and flange. A heat insulating ultem nipple (Honeywell part R-518-12) or insulating locking coupler adapter (R-518-PT12 or R-518-PT12L) will reduce the conducted heat, but

direct radiation can cause the housing case temperature to exceed limits. If the ambient heat (direct radiation) is excessive, then a fiber optic extension should be considered. The extension uses a fiber optic cable assembly between the sight pipe and the viewing head, allowing the viewing head to be placed further away from the heat source. Refer to the Fiber Optic Manual 69-2683 or contact your distributor or the factory for assistance with fiber optic selection and pricing.

The model S55XB and S55XBE series of viewing heads have in place a sensor for sensing the internal temperature of the head, which can be displayed on the attached signal processor. For the P520/P522, press the “Reset” and the “Down” arrow key at the same time. The temperature reading will be displayed in the four-digit readout. The reading (indicated in °C) will disappear and the normal reading will continue after several seconds. For the P532, a dedicated key is provided for each S55XB/BE to display temperature.

Purge Air

Use a flexible air supply line, to allow for repositioning of the viewing head. A continuous flow of air must be maintained in order to reduce conducted heat and to keep the sight pipe and viewing head lens free of dirt and debris. Air required is about 0.13 Nm³ / min (5 SCFM) delivered at 25 mm (1 in.) above the maximum pressure as measured at the “Y” or “T” section of the purge air connection for each viewing head. The air supply must be clean, free of oils and water, and preferably cool. In order to electrically isolate the viewing head, the purge air line should be installed using an insulating material, such as a rubber hose, in between the purge air line and the viewing head.

Vibration

Do not install the viewing head where it could be subject to high vibration. Provide an anti-vibration mount if excessive vibrations are present.

Clearance

Make sure there will be sufficient room to remove the viewing head housing for servicing.

Mounting

Honeywell offers a range of swivel mounts, both pipe thread or flange mounting for use with sight pipes or direct windbox mounting. Refer to the Accessories section of this document or the Honeywell website for further details.

Viewing Head Sighting

The sighting of the viewing head should be parallel to the center line of the burner in the direction of the flame. If used, the sight pipe should be mounted as close to the center line as possible so as to sight along the flame rather than across the flame. Doing so will ensure continuing flame detection under changing load conditions. Refer to Fig. 6, 7, and 8.

Utilizing a sighting or the sight pipe aimed at the root of the flame (where the turbulent combustion air mixes with the flame) is a good starting point for optimizing the sighting. Where practical, using a swivel mount to “zero-in” on the highest signal will assure maximum performance. The

optimum scanner location is parallel to the burner center line. The use of a swivel mount allows for line of sight adjustment, where practical to use.

Examples of viewing head installation with and without a swivel mount are shown in Fig. 9 and Fig. 10. If using a sight pipe, the diameter should be large enough to allow a reasonable field of view, and to allow for adjustment of the swivel mount angle. The S550B/BE has two angles of view, one for the IR detector, which is 1.0° and one for the UV detector which is about 3.0°; this translates into a circle of view that varies with the viewing distance as shown in the following table.

Table 3. Circle of View.

Distance in ft (m)	Distance in in. (cm)	Diameter of IR View in in. (mm)	Diameter of UV View in in. (mm)
2 (0.6)	24 (61.0)	.64 (16)	1.3 (33)
3 (0.9)	36 (91.4)	.73 (19)	1.9 (48)
6 (1.8)	72 (182.9)	1.45 (37)	3.8 (97)
12 (3.6)	144 (365.8)	2.9 (74)	7.6 (193)
18 (5.5)	216 (548.6)	4.35 (110)	11.4 (290)

As an example of proper sighting challenges, detecting flame in a sulfur recovery unit can present a challenge for IR flame monitors. The IR detector will detect natural gas used for the warm-up of the reactor. Usually the combustion air is turbulent enough to cause a good flicker signal.

When the sour gas is introduced and the natural gas is shut down, the flame signal could drop off or drop out entirely due to a complete change in the flicker content for the existing viewing head sighting. In this case, optimizing the flame signal for the sour gas by “zeroing-in” on this flame, and not the warm-up burner may be beneficial.

Once optimizing the sighting for the sour gas has been completed, the signal level could be too low on the natural gas. In this case, using the UV detector for this application may be beneficial. It may be beneficial to use two sets of set points for flame ON and flame OFF, one set for proving and detecting the natural gas flame and the other for proving and detecting the sour gas flame. The switch-over from Channel A to Channel B should be done when removing the natural gas burner. The switch-over can be implemented from the burner control system. The switch-over and the use of Channels A and B with their independent settings is explained in the applicable signal processor manual.

ACCESSORIES

Orifice disks (kit M-702-6)

Used to reduce the signal brightness in cases where the signal brightness is too strong. Located immediately in front of the lens, it will reduce the amount of signal to the sensors. Bag assembly contains orifice disks and retaining rings. Orifice disks come with 3/8, 1/4, 3/16 and 1/8 inch diameter holes. Contact the factory for guidance in using orifice disks.

Insulating nipple (R-518-12)

1 in. NPT Ultem heat and electrical insulating nipple typically used in conjunction with a swivel mount or isolation unit.

Swivel mounts (M-701-1, M-701-2, M-701-2-FLG, M-701-2-SS, M-701-3, M-701-3P, M-701-4)

All have 1 in NPTF viewing head connections on one end with varying process connections including 2 in. pipe slip on, 2 in. NPTF, 2 in. flanged, 2 in. NPT in stainless steel construction, 4.5 in. flanged with 3 bolts, 3 in. NPTF and 2-bolt flanged.

Insulating locking coupler adapters (R-518-PT12, R-518-PT12L)

1 in. NPTM Ultem adapters insulate the viewing head electrically and thermally and are used with the R-518-CL12-PG purge air adapter or the R-518-CL12-HTG locking coupler. The R-518-PT12L has a quartz lens.

Locking coupler (R-518-CL12-HTG)

Used with the R-518-PT12 and R-518-PT12L insulating locking coupler adapters. Process connection end in 1 in. NPTF.

Locking coupler with purge port (R-518-CL12-PG)

Adapter is a 1 in. NPTM locking quick disconnect/cam and groove coupler with 1/2 in. NPTF purge port. Used with R-518-PT12 and R-518-PT12L insulating locking coupler adapters.

NOTE: The S55XB/BE models have a built-in 1/2 in. NPTF purge port.

Connector (R-518-11)

Not Recommended for new installations. Replacement field wireable viewing head connector with insulating sleeve, accepts wire size (Honeywell C330S, 6–8mm).

Connector (R-518-09)

Not Recommended for new installations. Replacement field wireable viewing head connector with insulating sleeve, accepts wire size Honeywell C330 or C328, 10–12mm.

Cable (C330S) Yellow

4 conductor, 22g with foil/braid shield and shield drain. Sold per foot.

Cable (C330) Blue

Not recommended for new installations. 4 conductor, 18 g + single wire braid shield.

Isolation Units (ISO-UNIT, ISO-UNITSS, ISO-UNITHPGT)

All have 1 in. NPTF connections with 1/2 in. NPTF purge ports and quartz window. Painted aluminum or stainless steel construction. The HPGT version has a 1/2 in. thick quartz window for higher pressures.

Air cooling canister (ACC5XX)

For S55XB models only. 1/4 inch air inlet port. Use with vortex coolers.

Vortex coolers (M3204, M3208, M3210, M4025)

Used with air cooling canister. Contact your distributor or the factory for selection assistance.

Cable restraints (S5XXCR, S5XXCRLT)

Standard and liquid tight cable restraint versions.

Fiber Optic System Compatibility

The S55XB/BE viewing heads are compatible with the Honeywell FASA fiber optic extension products. The S550FOAD, S550FOADY-FT and S550FOADY-FT-AL adapters are applicable. Contact your distributor or the factory for assistance with fiber optic selection and pricing.

OPERATION

IR Detector

The IR solid state detector in the S550B/BE and S552B/BE viewing heads responds to IR radiation/flicker in the flame. Flame flicker is caused by the combustion, or forced air injected into the flame. This combustion air can be mixed with the fuel (pulverized coal) or can be introduced separately. In either case, forced air is introduced in such a way as to aid the combustion process. This air is usually made turbulent by causing it to swirl with spin vanes located in the burner barrel. Flame flicker is created when turbulent air mixes with the flame. It is composed of random frequencies and the amount of high frequency flicker is dependent on the fuel and burner.

The S550B/BE and S552B/BE viewing heads respond to flicker frequencies 16 Hz and above. The lower frequencies are ignored so it is important to sight the viewing head on the highly turbulent portion of the flame that contains the higher frequencies. The location of the higher frequencies can be predicted by examining the burner with regard to where the flame envelope begins and where the turbulent air enters the flame. The optimum scanner location is parallel to the burner center line. The use of a swivel mount is encouraged to allow for line of sight adjustment.

UV Detector

The UV tube detector in the S550B/BE and S556B/BE viewing heads have a spectral response of 190-215nm. The output of the detector is a pulse stream of randomly spaced pulses whose average rate is proportional to the UV radiation present in the flame.

The spectral range of the UV tube makes it ideal for discriminating between flame and glowing refractory. As with any UV radiation, it can be absorbed or masked by pulverized coal, unburned fuel, smoke, oil mist, dirt, dust and other impurities in the fuel. As well, sour gas (H₂S) can readily absorb 200nm UV wavelengths, reducing the amount of ultraviolet radiation reaching the detector. Care should be taken to select the proper viewing head for the fuel used. Additionally, the contaminants that mask UV can be diluted by providing a strong flow of air through the sight pipe to clear a viewing path through the attenuating material. Refer to the Purge Air section of this manual.

It may also be desirable to sight the detector at an area containing fewer masking agents such as near the burner nozzle or near the entrance of the combustion air. Increasing the viewing area of the detector by shortening the sight pipe or by increasing the diameter of the sight pipe can also reduce the attenuating effects of masking agents.

In general, the UV viewing heads will work well on natural gas and light oil fuel flames. The sighting for both oil and gas flames should be parallel to the axis of the burner and aimed at the root of the flame, as with the IR detector. (See previous section "IR DETECTOR".) The highest UV intensity occurs near the root of the flame. In addition, the zone of higher UV intensity does not overlap the same zones of adjacent or opposing burners so that, with proper sighting, discrimination can be achieved.

With low NO_x gas burners, the UV radiation is usually much less in intensity and spread out. Relatively high readings can be obtained from all over the furnace when many burners are

on. This is particularly true when flue gas recirculation is used. There will however, be a relatively stronger signal near the “root” of the flame and the more intense spot should be located during the aiming or sighting process. This “root” or intense spot may be further out than with the standard gas burner so it is imperative that a swivel mount be used when making sighting adjustments.

Another factor that needs to be considered when aiming the viewing head is the load condition of the boiler. The flames from a burner can be radically different at different loads. This is one of the reasons for choosing an optimum sighting initially that will minimize signal swing due to changing loads.

Self-Checking

The self-check circuitry guards against internal component failures. There are several tasks that require intelligent interaction between the viewing heads and the signal processor. If all of the interactions do not occur properly, the viewing head will not send pulses back to the signal processor and the flame relay will open.

Verifying the validity of the gain code received is one of the tasks performed by the processor in the viewing heads. The self-check pulse from the signal processors is a 100ms-wide, 20V to 24V pulse with two “notches” or breaks in it. The position of each of the two notches communicates a gain code one to nine plus parity to the viewing head. The viewing head sends back an ID pulse in the first half of the 100ms self-check time. One viewing head expects to receive data with one parity and the other expects to receive data with the other parity. If a viewing head does not receive its correct parity plus the gain code once per second, it produces no output pulses.

Orificing

Orifice disks have been used in applications with older viewing heads that did not have adjustable gain in order to reduce the extreme brightness of certain burner flames. Orifice disks come with 3/8, 1/4, 3/16 and 1/8 inch diameter holes. Contact the factory for guidance in using orifice disks. The discs are installed with retaining rings in the flange at the edge of the 1/2 inch NPT female pipe thread for the purge air. An internal type retaining ring is first installed by positioning a ring in the machined groove inside flange opening from the housing side. The orifice disc is then inserted. Use a second retaining ring to hold it in place so that it is sandwiched tightly between the two retaining rings.

Default Settings For the S550B/BE

A new signal processor will set the attached viewing head default values as follow:

- UV Gain = 32 (out of 0-99 range)
- Filter = Filter 3 (high pass above 33Hz)
- IR Gain = 451 (out of 0- 699 range)

These are nominal settings that should allow for initial sightings and adjustments. Both UV and IR sensors are active in the default mode. If the settings for the viewing head has been changed from the default values, they can be reset to the factory default from the P522 / P532 control panel. (See “RETURN TO DEFAULT SETTINGS.”)

NOTE: The following sections referencing the P520, P522, P531 and P532 signal processors are for reference only. For detailed viewing head programming and adjustment instructions, refer to the appropriate signal processor manual.

Stored Viewing Head Settings

Viewing Head settings are stored in an EEPROM in the particular signal processor to which it is attached. In the event of a power down or power loss, these settings will be restored upon power up. If an S550B/BE viewing head is replaced with another, the stored settings will be applied to the replacement upon power up of the signal processor.

S55XB/BE Setup

For setup of the S55XB/BE viewing heads, refer to the appropriate signal processor manual. The S55XB/BE viewing heads are compatible with the P522, P531 and P532 signal processors.

MAINTENANCE (UV TUBE MODELS ONLY)

The UV sensor has a limited lifespan. Under extreme conditions, the lifespan can be as low as 10,000 hours. However in the most favorable conditions, the lifespan is 50,000 hours or more. The service life of the UV sensor is considered terminated when the sensitivity becomes lower than 50% of the initial value. A monthly sensitivity check is suggested to determine if the UV sensor’s life is terminated. The reading of the signal processor digital display should be compared to the initial reading of the unit when it was installed. Ensure similar burner fire conditions of the application, and that the same gain settings of the viewing head, are used during each sensitivity check. If it is determined that the sensitivity is below 50% of the initial value (terminated life of the sensor), the sensor should be replaced.

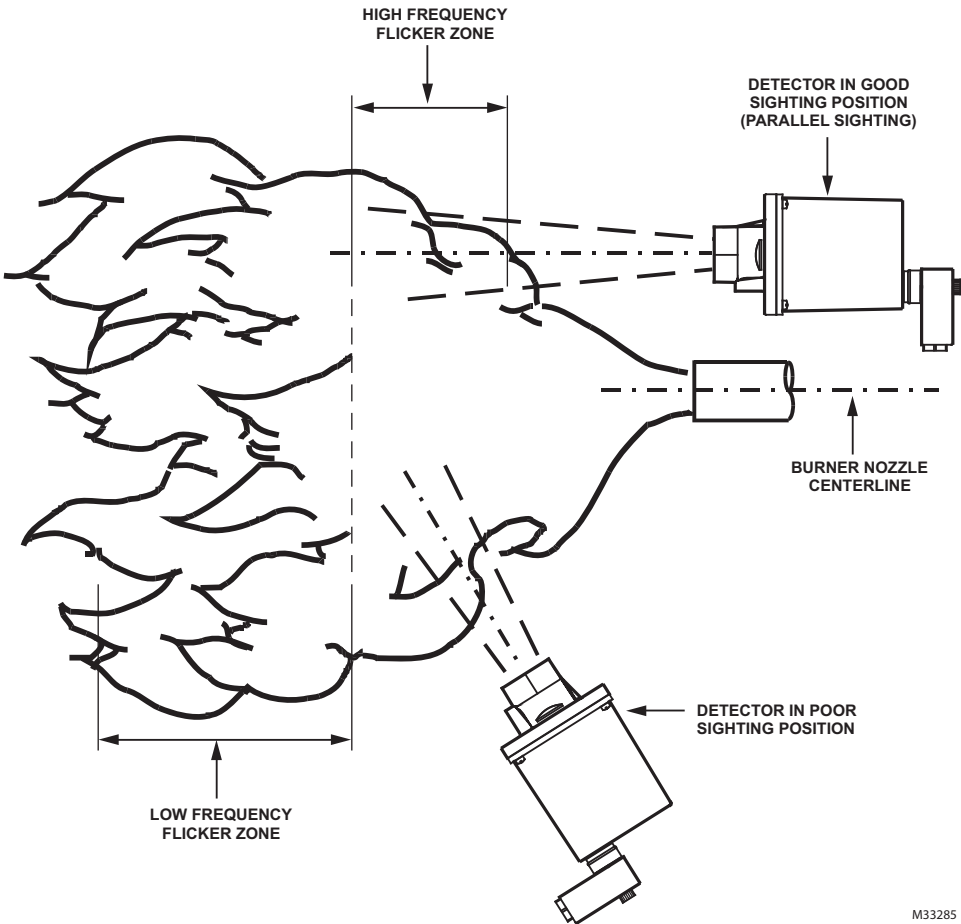
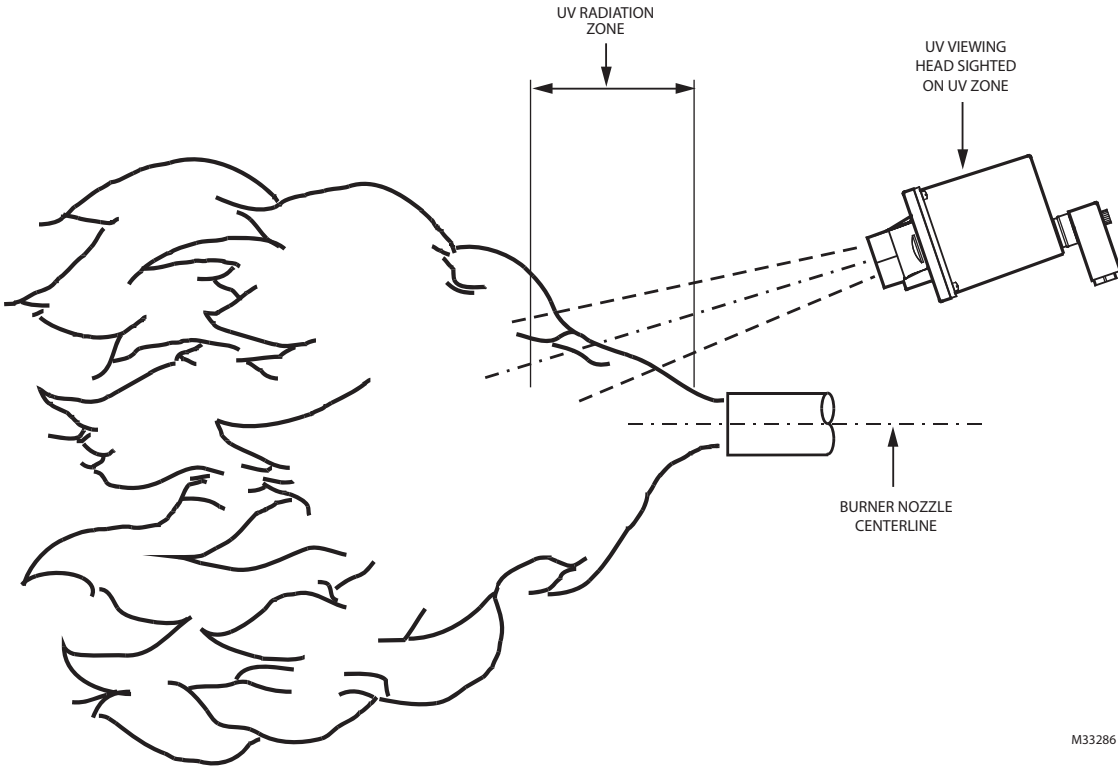

Fig. 6. IR viewing head location.

M33285



M33286

Fig. 7. UV viewing head location.

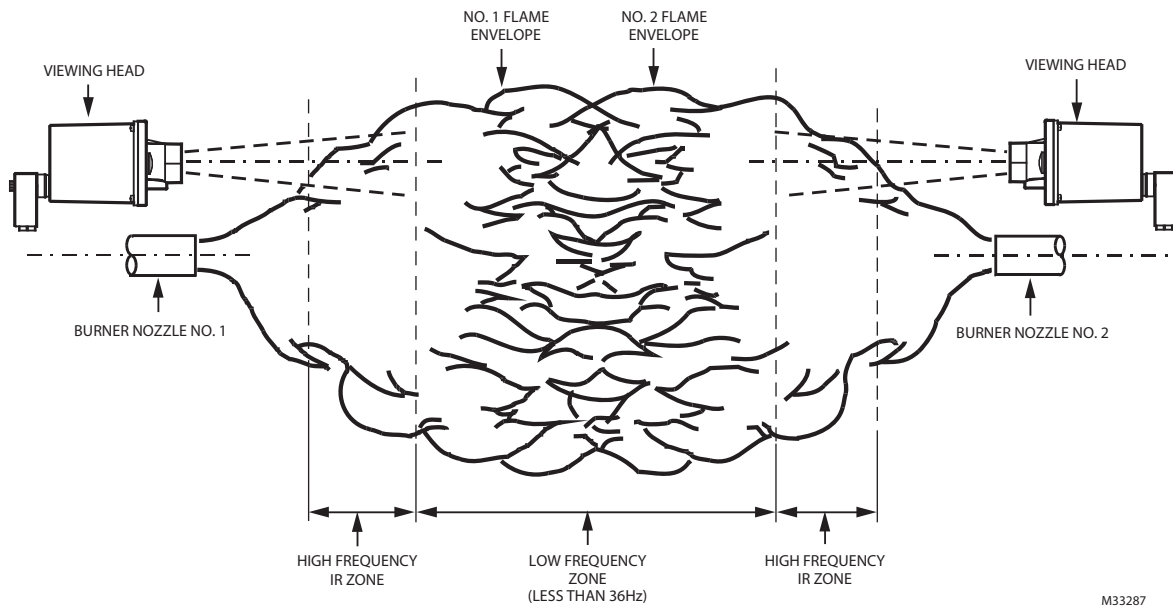

M33287

Fig. 8. Sighting opposed fired burners.

Mounting Examples

For electrical and heat insulation requirements, the Honeywell R-518-12 nipple, the R-518-PT12 or R-518-PT12L locking coupler adapter accessories or similar product must be used for mounting, attached directly to the S55XB/BE viewing head. Cooling air should be provided via the purge air connection to reduce conducted heat and to keep the sight pipe and viewing head lens free of dirt and debris. Refer to the "Mounting and

Sighting" on page 7 on purge air requirements. For electrical isolation reasons, the purge air line should be installed using an insulating material, such as a rubber hose, in between the purge air line and the viewing head. Note that an extension pipe may be required to locate the viewing head further from the burner front plate to avoid high temperatures.

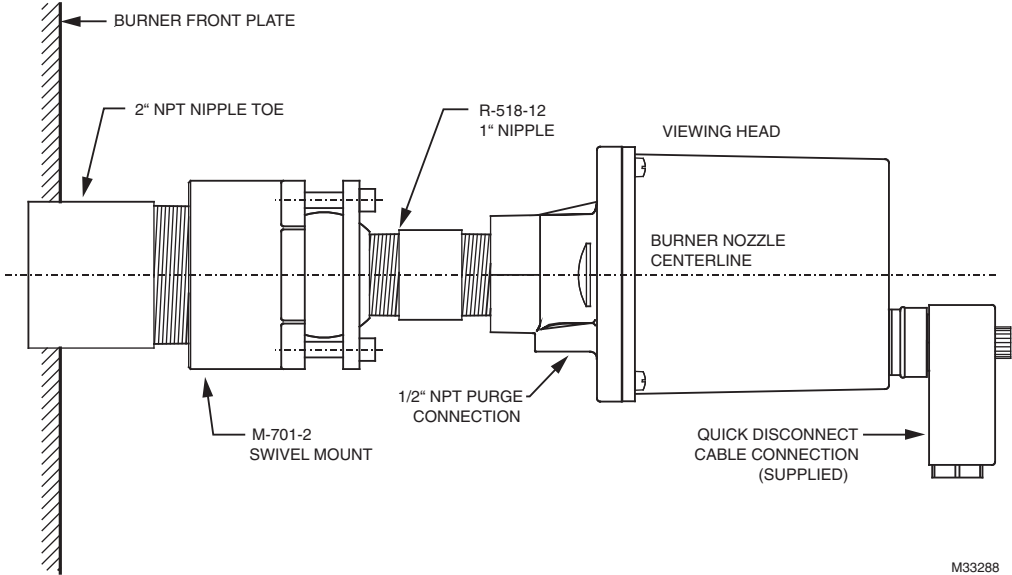

Fig. 9. Viewing head mounting example.

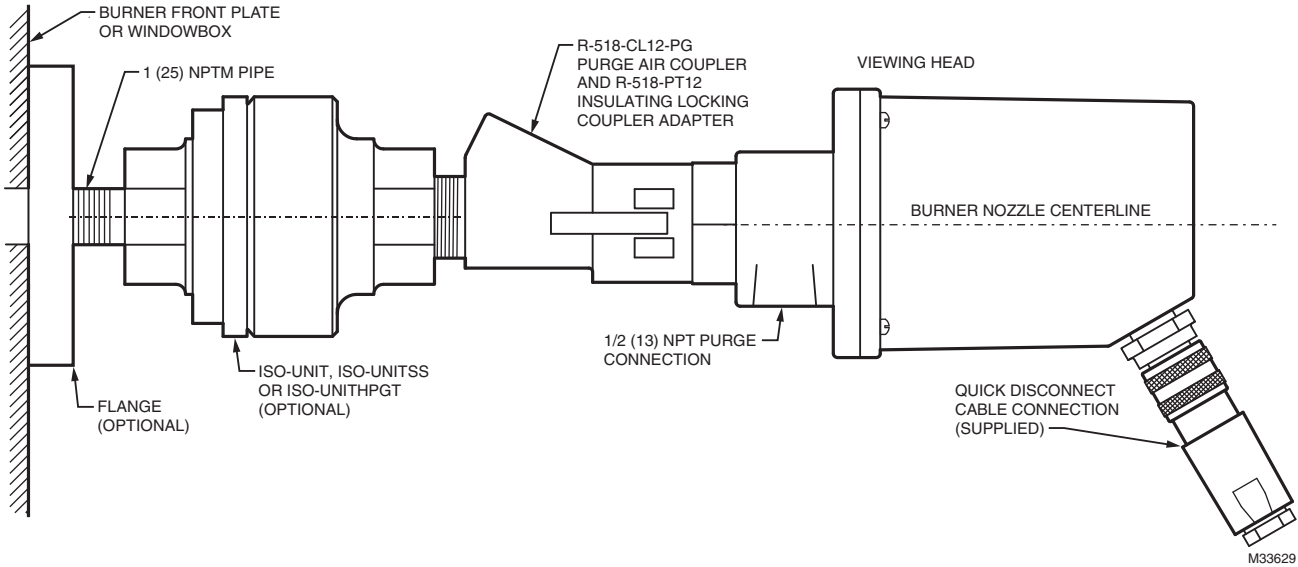

Fig. 10. Viewing head mounting example 2.

SAFETY MANUAL

S55XB and S55XBE Product Declaration

FIT FOR USE IN LOW DEMAND SAFETY APPLICATION

Models: S550B, S550BE, S550BE-PF, S552B, S552BE, S552BE-PF, S556B, S556BE, S556BE-PF

Models	SIL	HFT	PFD	SFF	λ_S	λ_{DD}	λ_{DU}
S550B, S550BE, S550BE-PF	3	0	1.98×10^{-4}	>99%	1.06×10^{-5}	8.07×10^{-9}	9.06×10^{-9}
S552B, S552BE, S552BE-PF	3	0	1.83×10^{-4}	>97.4%	3.09×10^{-7}	8.07×10^{-9}	8.39×10^{-9}
S556B, S556BE, S556BE-PF	3	0	1.93×10^{-4}	>99%	1.04×10^{-5}	8.07×10^{-9}	8.31×10^{-9}

System Architecture	1oo1
MTTR	8 hours
Proof Test Interval	5 years
Fit for use in	SIL 3 environment

Definitions

Term	Definition
Dangerous Failure	Failure that has the potential to put the safety-related system in a hazardous or fail-to-function state.
Safety-Related System	A system that implements the safety functions required to achieve or maintain a safe state and is intended to achieve on its own or with other systems the necessary safety integrity for the required safety functions.
Safety Function	Defined function that is performed by a safety-related system with the aim of achieving or maintaining a safe state for the plant, in respect of a specified hazardous event.
Proof Test	Periodic test performed to detect failures in a safety-related system so that, if necessary, the system can be restored to an "as new" condition or as close as practical to this condition.
MTTR (Mean Time to Restoration)	The average duration required for restoration of operations after a failure.
λ_{sd}	Rate of safe detectable failures per one billion hours. For example, if $\lambda_{sd} = 3000$, then it is estimated that there will be about 3000 safe detectable failures during every one billion hours of operation. For $\lambda_{sd} = 3000$, this is about one safe detectable failure every 38 years.
λ_{su}	Rate of safe undetectable failures per one billion hours.
λ_{dd}	Rate of dangerous detectable failures per one billion hours.
λ_{du}	Rate of dangerous undetectable failures per one billion hours.
System Architecture	Specific configuration of hardware and software elements in a system.
PFD _{AVG} (Average Probability of Failure on Demand)	Average Probability of Failure on Demand. In this case regarding S550B, S550BE, S550BE-PF, S552B, S552BE, S552BE-PF, S556B, S556BE, and S556BE-PF Signal Processors.
FIT (failures in time)	A unit of measurement representing one failure per one billion hours. 1,000,000,000 hours is approximately 114,155.25 years.

Safety Function of the S55X family

The S55X family viewing heads do not have a safety function. They are used to provide flame intensity information via cables. Signal Processor Models 522AC, 522DC, 531AC, 531DC, 532AC, and 532DC, which use Flame Relays to provide a safety function.

Proof Test Interval

The proof test must be conducted every 1 to 5 years. This range is given to allow for the test to be performed during the normally scheduled burner shutdown period. It is the responsibility of the user to perform the proof test in the specified time frame.

The following diagram for S550BE shows the dependence of PFD_{AVG} on the proof test interval. PFD_{AVG} increases as the proof test interval increases.

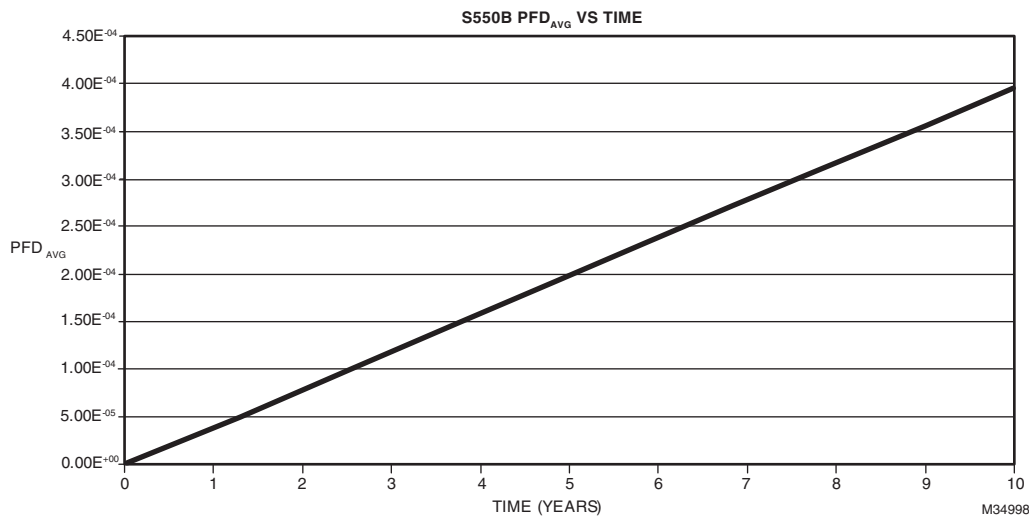

Fig. 11. S550B PFD_{AVG} vs Time.

Proof Test Procedure

Equipment

1. P522 or P532 Signal Processor connected to S55xB, or S55xBE viewing head.
2. DC power supply for DC and AC power supply for AC model.
3. A source capable of generating UV or IR signals as required.

NOTE: For UV use Honeywell UVsource. For IR connect incandescent lamp to AC source.

Setup

1. Ensure the S55X family processor viewing head under test is correctly connected to a compatible signal processor.
2. While performing the proof test, disconnect or disregard the signal processor outputs so that any outputs due to testing do not affect the overall safety system and potentially cause a hazardous situation.
3. Record all previously entered user programmable settings so that you can restore them to their desired values after the proof test.

Tests

NOTE: The S550B and S550BE viewing heads have both infrared and ultraviolet sensors, therefore the tests in steps 1, 2, and 5 must be performed once with an infrared light source and once with an ultraviolet light source.

1. Apply power to the signal processor, fully illuminate the viewing head with the light source, and ensure that a flame on condition is indicated by the signal processor.
2. Gradually angle the light source away from the viewing head. Ensure that the count decreases until a flame off condition is indicated by the signal processor.
3. Cover the end of the viewing head with your hand and ensure that the signal processor indicates a flame count of zero.
4. Use your light source to generate flame counts of between 1200 and 2800 on the signal processor. Note the flame count.
 - a. Increase the UV or IR gain (whichever is appropriate for your sensor and light source) and store the settings. Ensure that the flame count increased.
 - b. Decrease the UV or IR gain (whichever is appropriate for your sensor and light source) and store the settings. Ensure that the flame count decreased.
5. Restore all original settings as recorded in Setup and reconnect the signal processor to the safety system.

Product Decommissioning

When required, decommissioning of S55X family processors should be performed in accordance with the requirements of the overall safety system.

Automation and Control Solutions

Honeywell International Inc.
1985 Douglas Drive North
Golden Valley, MN 55422
customer.honeywell.com

© U.S. Registered Trademark
© 2014 Honeywell International Inc.
66-2064—03 M.S. Rev. 03-14
Printed in United States

Honeywell